

Where Are We Heading?

Steve Lampen
Consultant



You Are Not Alone

- Everyone is heading in this direction
 - AM broadcasters
 - FM broadcasters
 - VHF broadcasters
 - UHF broadcasters
 - Production houses
 - Post-production houses
 - Effects houses
 - Recording studios
 - And many, many more.....

Digital Has Won

- Everything starts in analog
 - Our ears are analog
 - Our eyes are analog
- But digital versions of these signals are....
 - Easier to duplicate
 - More precise in their duplication
 - Easier to distribute
 - With no limit to the number of distribution points
 - Quality as good as analog, some might say “better”
 - Delivered content can DEFINITELY be better quality

It Doesn't Matter What Your Content Is

- Everything is data
- If you need better quality, use more data
- If you have wide bandwidth content, use more data
- If you have complex duplication and distribution, use more data

And Here's How it Will Look – this is a Data Center



This is a TV Station



This is a Radio Station (maybe less racks)



This is Factory Floor Automation



This is Theatrical Lighting Controls (maybe less racks)



Or maybe this is 10,000 racks in Antarctica? The cloud?



Do you really care where they are?



As long as you can put your signals in?



And get your signals out (with the best quality ever?)



The First Salvo is the Outside Compute Platform (OCP)

- An idea launched by Mark Zuckerberg and Facebook
 - “What if you didn’t need to use anything that came before?”
 - “What if you could design your requirements from the ground up?”
 - “What would they look like?”

The Original “Relay Rack”



The Original “Relay Rack”

- 1911
- Railroad track relays
- 10/32 screws (sometimes 10/24)
- 19” wide (sometimes 24”)
- We’ve been stuck ever since!
- Anything else was NON-STANDARD



Open Compute Rack V1.2

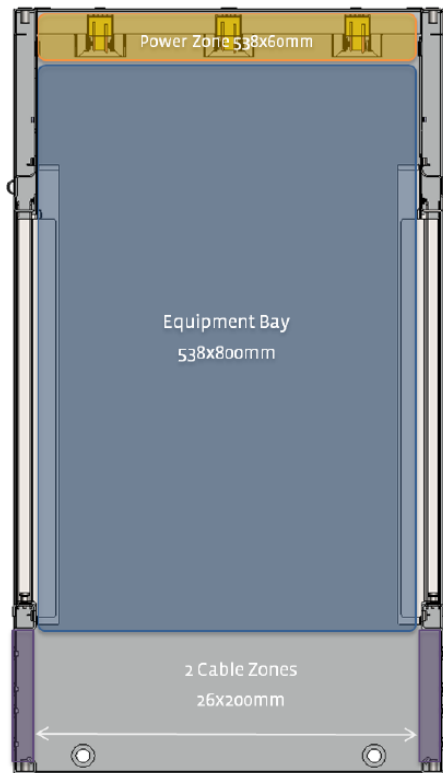

Data Center Air Flow

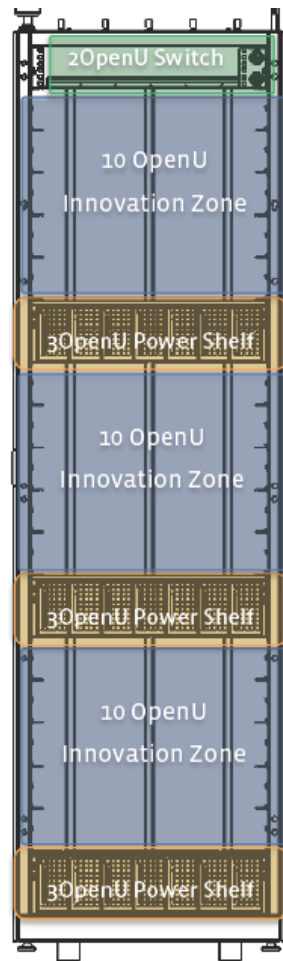

Open Compute v3

- Reuses the "v2" half-width motherboards
- Self-contained sled for Open Rack
- 3-across 2U form factor enables 80mm fans with 45 servers per rack

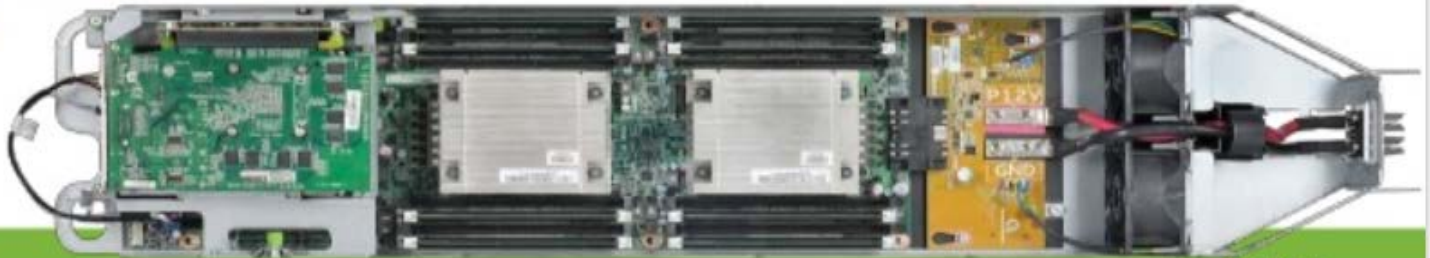

OPEN
Compute Project

An OCP “Server”

- It contains
 - Some memory
 - Some processing
 - Some distribution
 - Some specialized hardware (you will have input)
- What if I need more memory? More processing?
 - You will use as many processors as you need to get the job done
- The only difference will be the software you use
 - Specialized software for audio and video recording, reproduction

Innovative Shared 12v DC power system

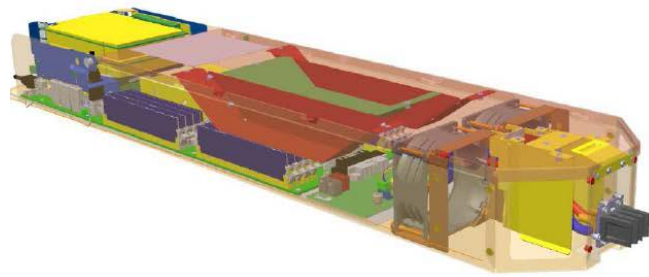

Alignment Pin catches between the busbar

Float +/- 4mm horizontal
Float +/- 3mm vertical

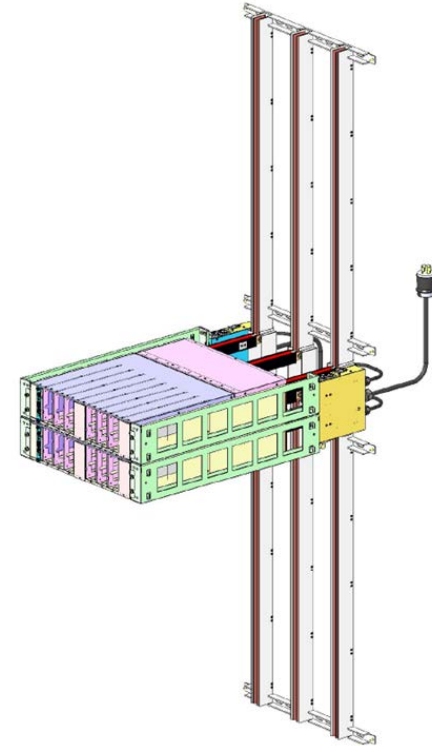
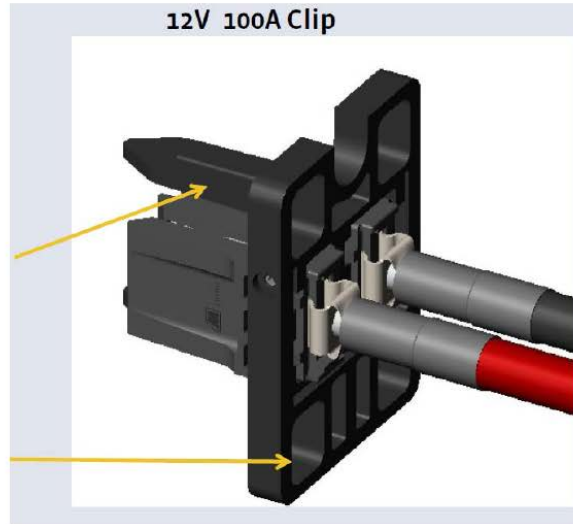

The Goals of OCP

- Resiliency not redundancy
- Minimize “critical points” in infrastructure
- Maximize compute power
- Minimize heat/Maximize cooling
- Maximize versatility
- Any software overlay
 - And an audio or video software package will be common
 - Even though the Data Industry is >100 times bigger than Broadcast

Inputs and Outputs

- You will feed signals in to this data center.
- You will take signals out of this data center.
- Signals will be fed to you transmitter sites and transmitted.
- Signals will be fed to your on-line sites and “transmitted”
 - They will be more error free, robust and higher quality than ever before.
 - Your customers will be happier with the quality and reliability
 - The most casual viewer won’t even notice the change

How This Works

- Someone builds an OCP data center
- Some of these racks handle your signals
 - Which racks are yours?
 - I doesn't matter
 - How many racks will you require?
 - I doesn't matter
 - Sometimes a lot of racks
 - Sometimes a few racks
 - You'll get a bill for what you did use

Point to Your Broadcast Facility

- You can't – it no longer exists
- You might not even know which data center you're in
 - Maybe you're in a bunch of data centers
- You send your signals in and they come out and on the air.
 - What else do you need to know?



steve.lampen@belden.com

Belden.com | @BeldenInc